

# Assembly Manual

## QuickRelease Bar System for Roof-Top-Tents

fig 6. How the top bar fits onto the bottom bar.

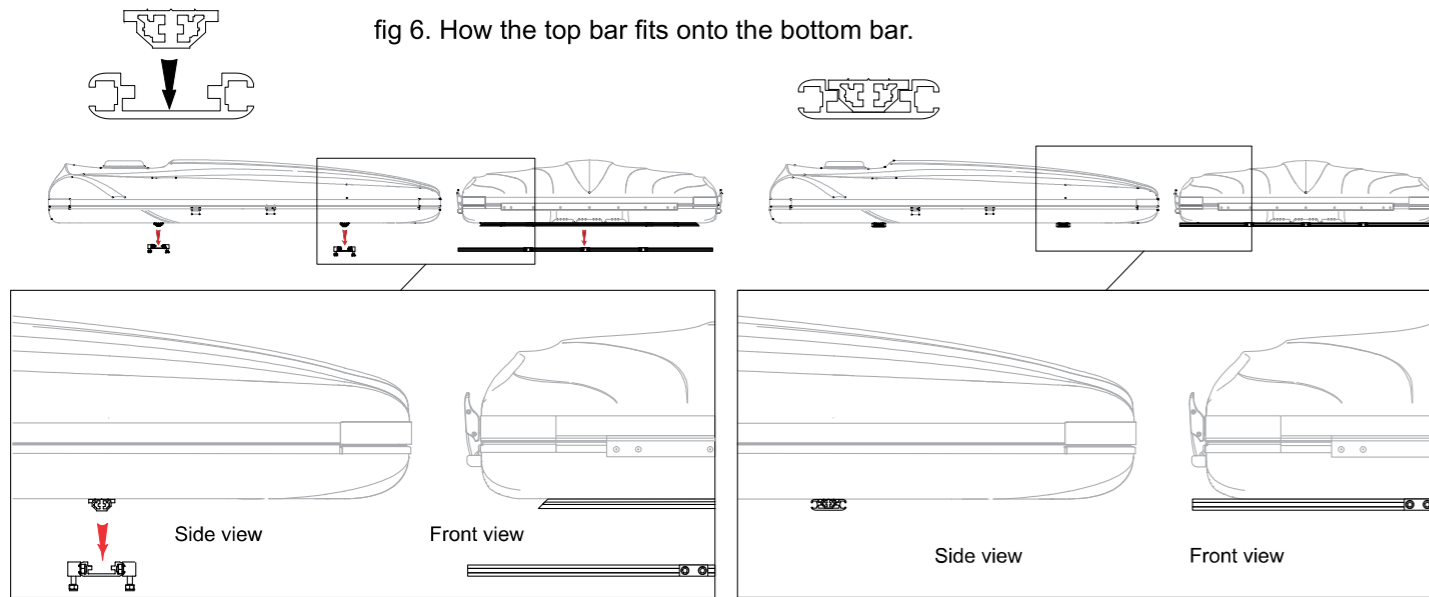

### 3.5 Mounting Fixers/Blockers and End Covers (fig. 7)

1. Slide the fixers/blockers onto the lower bar until they touch the upper bar.
2. Insert the M8 120 mm Allen screws.
3. Tighten firmly to lock the tent against upward and sideways movement.
4. Place the end covers for protection and finishing. (fig. 8)

fig 7. How to mount the fixer/blocker and the end cover

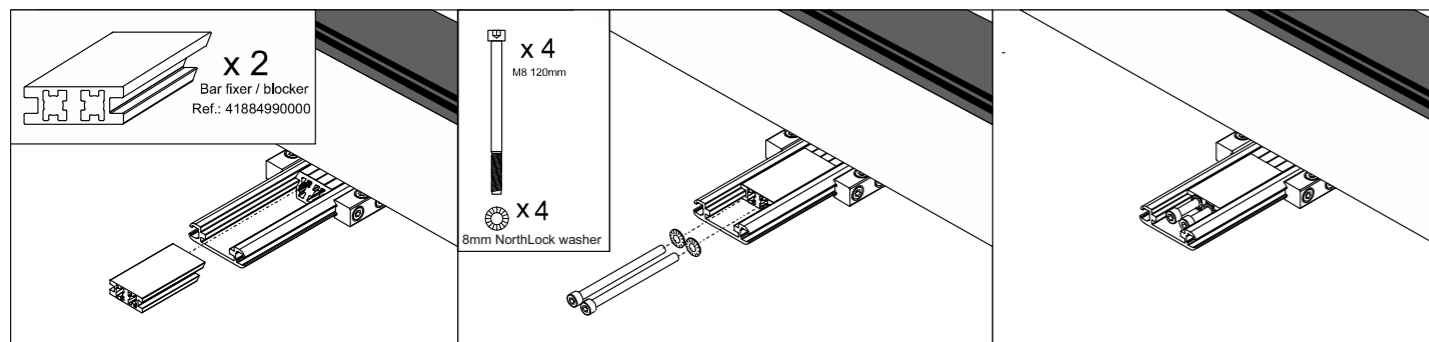
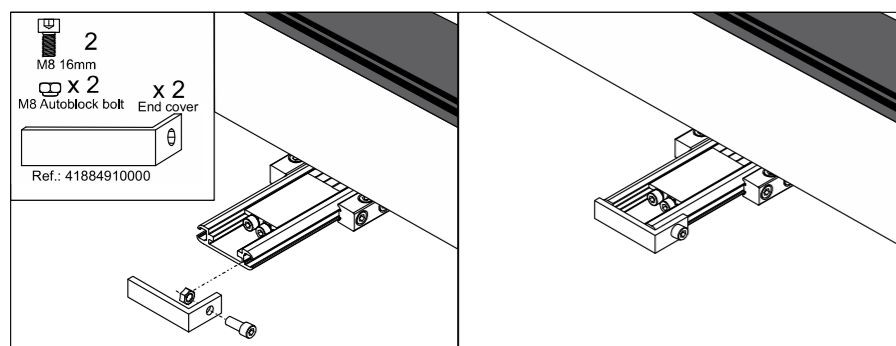

fig 8. End Covers



### 3.6 Disassembling the Tent

1. Loosen the fixers/blockers by unscrewing the Allen screws.
2. Remove the fixers/blockers.
3. Lift the tent, separating it from the lower poles.

### 4. Safety Recommendations

- Never use only one quick-release. Always install at least 2 or 3 units.
- Before each trip, check that all parts are correctly fitted and tightened.
- Do not exceed the maximum weight recommended by the tent or platform manufacturer.
- Avoid use in extreme conditions (strong wind, snow, severe off-road) without prior inspection.
- Periodically check the condition of the parts (screws, rails, and locks).

### 1. Introduction

The quick-release system was developed to facilitate the quick attachment and removal of roof tents on bars and vehicle platforms. Traditional methods using clamps or other fastening systems can be time-consuming and difficult to assemble. Installation is often challenging due to the perimeter of the platforms being closed and the reduced distance between the platform and the vehicle roof, which makes it difficult to place the clamps. For correct and secure fastening, two or three quick-release are required to attach a tent to the vehicle. This system eliminates the problems of traditional methods, offering practicality, speed, safety, and versatility.

### 2. Components

The package includes (fig.1) :

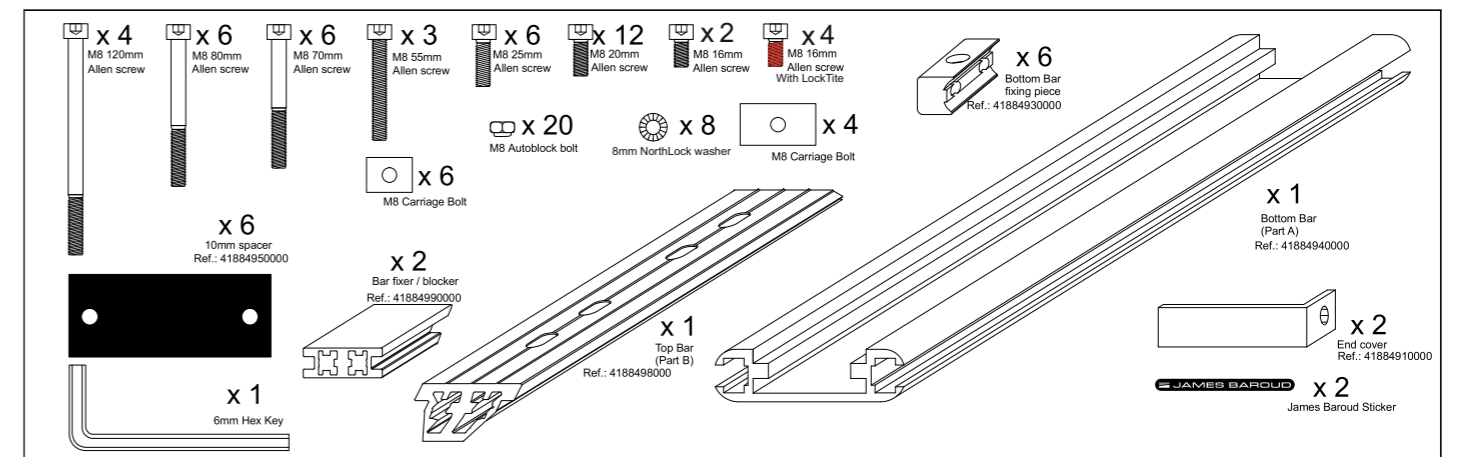

### 3. Assembly Instructions

#### 3.1 Install The bottom bar fixing Parts to the bottom bar (Fig2)

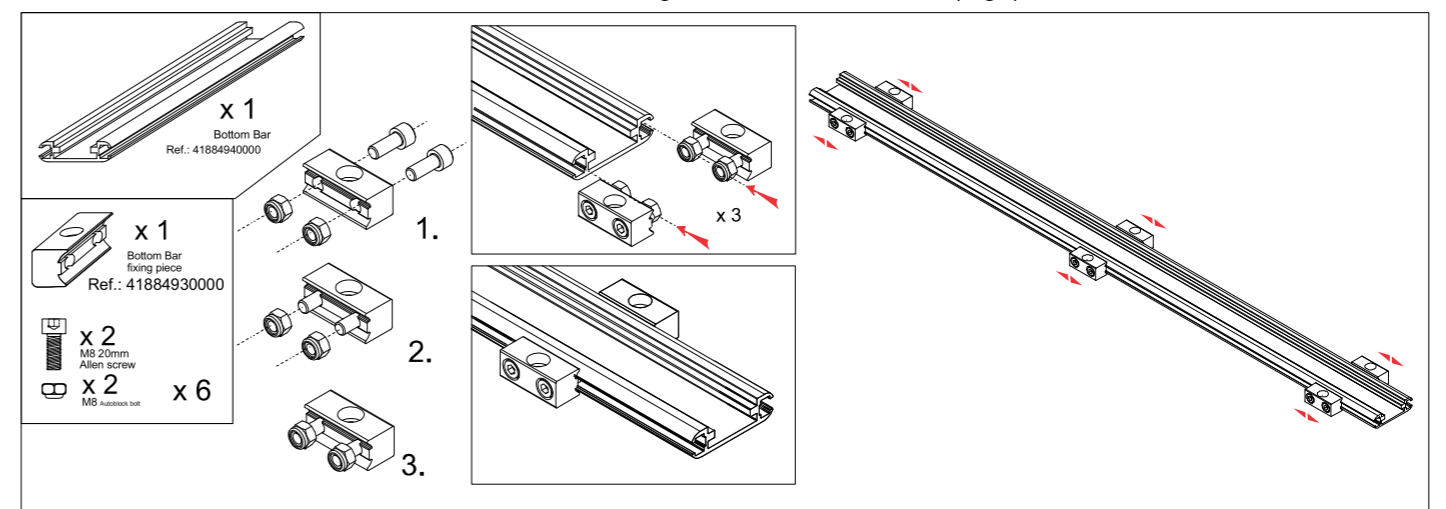

#### 3.2 Install Parts A (Bottom Bars) on the vehicle. Some examples (Figs. 3 and 4)

1. Position the bottom bars perpendicular to the vehicle (widthwise) and parallel to each other on the platform/crossbars.
2. Use the bolts and rails appropriate for each brand's system (Rhino Rack, Front Runner, ARB, Defender, Sherpa, etc.).
3. Securely fasten, ensuring there is no slack (not lose).

**Attention:** the measurement between the Bottom Bars on the vehicle and the measurement between the Top Bars on the tent must be exactly the same, otherwise the system will not fit.

fig 3. Some examples of assembly on different platforms

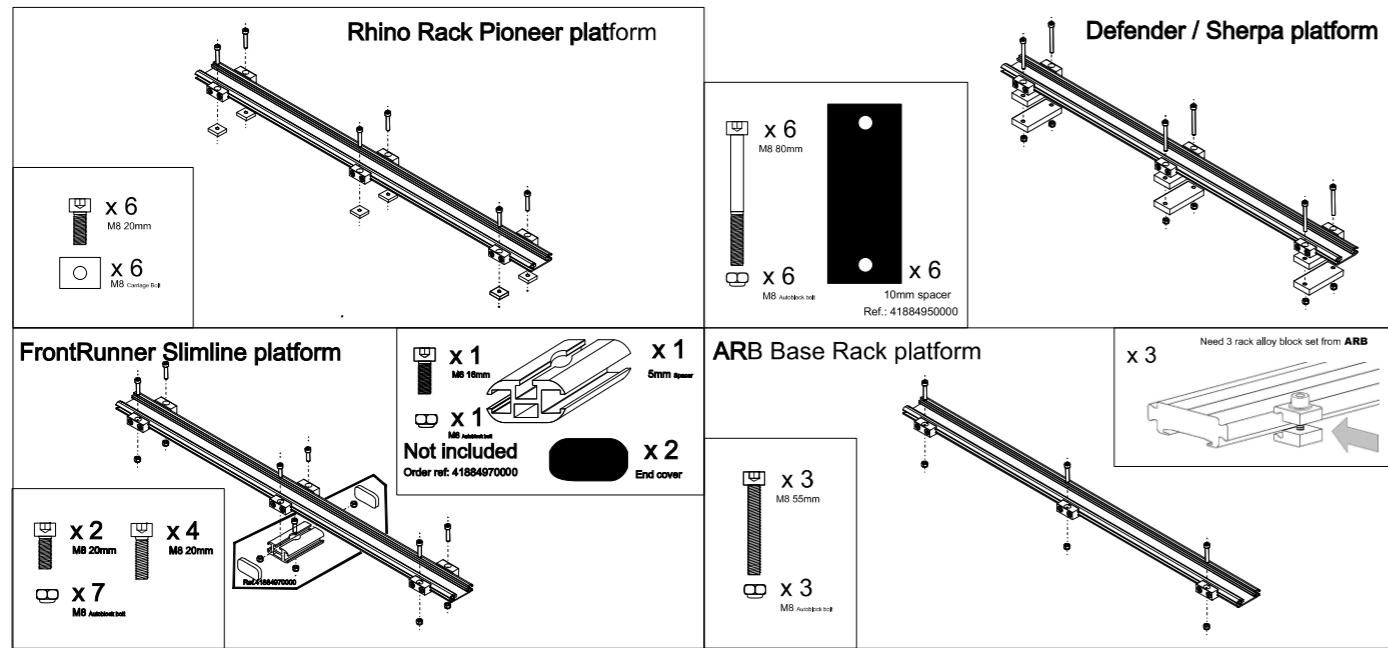
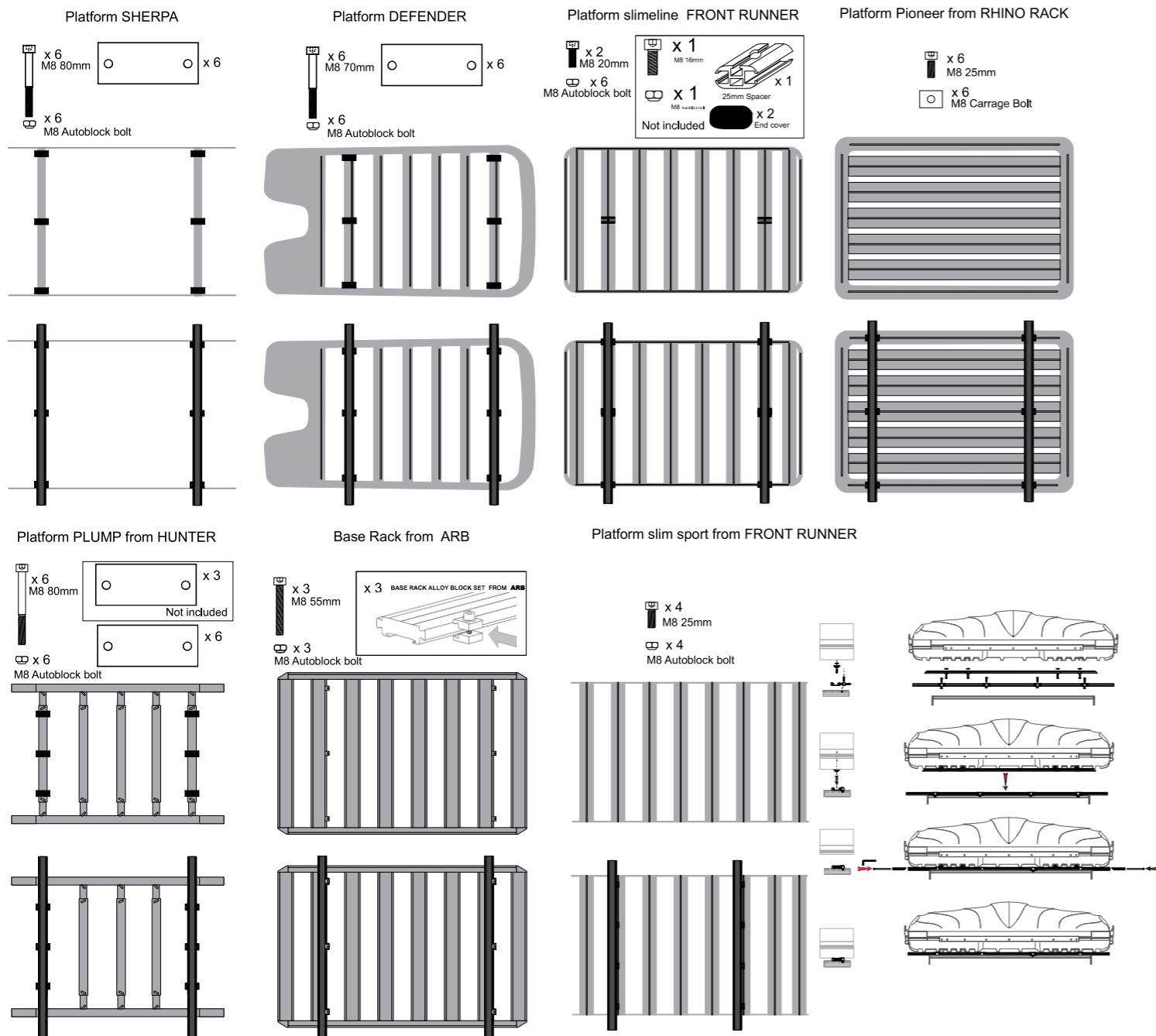

fig 4. Mounting quick release bars on common roof racks Components



3.3 Install Parts B (Top Bars) on the tent (fig. 5)

1. Secure the top bars directly to the base of the tent using the screws and rails provided.
  - Attention:** carriage bolts must be mounted across the tent rails (as shown in the figure) and never lengthwise.
  2. The bars must be mounted parallel to each other and perpendicular to the tent profiles.
  3. Confirm that they are correctly aligned and evenly distributed.
  4. Before finally tightening the screws, make sure that the bars are centered, i.e., that the distance between the sides of the tent and the bar is equal (on the right and left).
- Attention:** the measurement between the B bars (Top Bars) on the tent and the measurement between the A bars (Bottom Bars) on the vehicle must be exactly the same, otherwise the system will not fit.

fig 5. How to mount the top bar (part B) on the tent

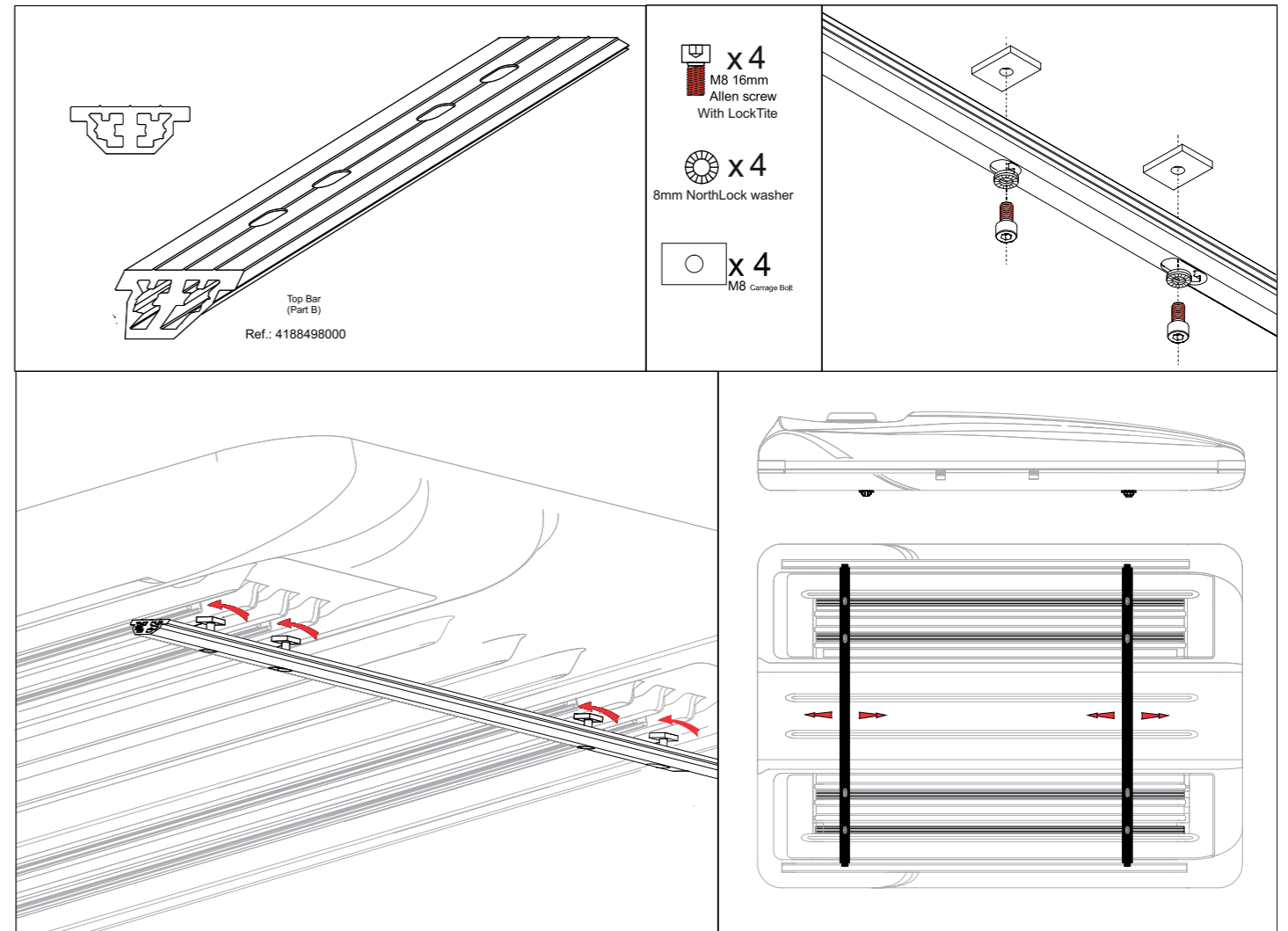

3.4 Fitting the System (fig. 6)

1. Align Parts B (on the tent) with the corresponding Parts A (on the vehicle).
2. Carefully slide the tent until all the upper bars fit simultaneously into the lower bars.
3. Confirm that it is secure by pressing and pushing the tent forward and backward.
4. Ensure that the tent is centered in relation to the lower bars.